

DRAG2ZERO

Gen2 BTA mount
for .66

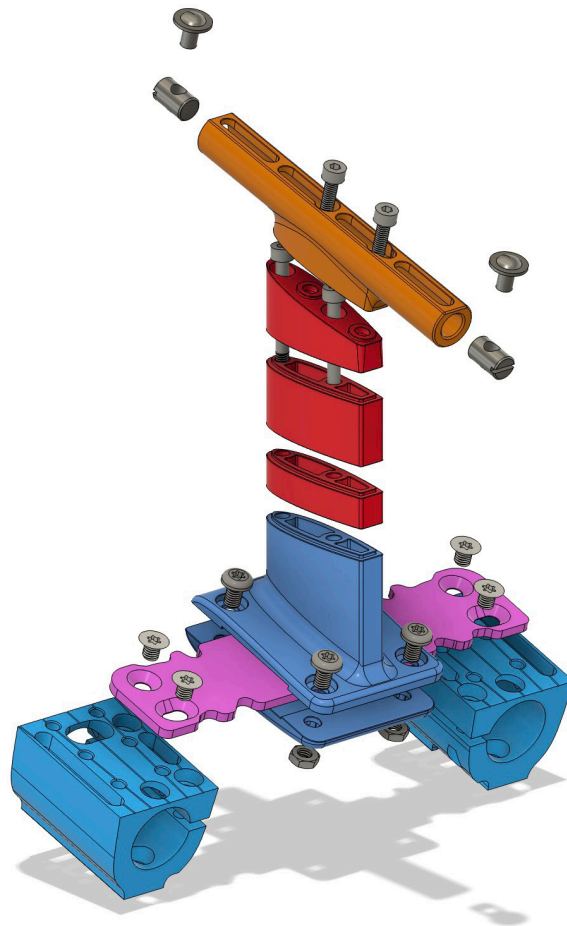

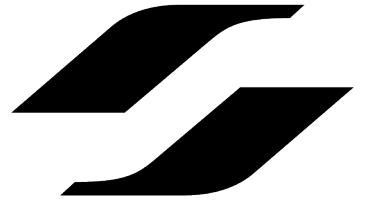

Parts List

1. BTA stack clamp
2. 20mm riser
3. 10mm riser
4. angled shim
5. bottle cage mount
6. BTA plates
7. 2 x M4 50mm caphead bolts
8. 2 x M4 30mm caphead bolts
9. 4 x M5 6mm countersunk bolts

Tools required

- T25 Torx key
- M4 Allen key



Step 1

Loosley clamp the BTA plates in the BTA stack clamp.





Step 2.a

Mounting with 2 armrest supports

If your armrest are mounted with two arm rest supports like so. Skip steps 3 and 4

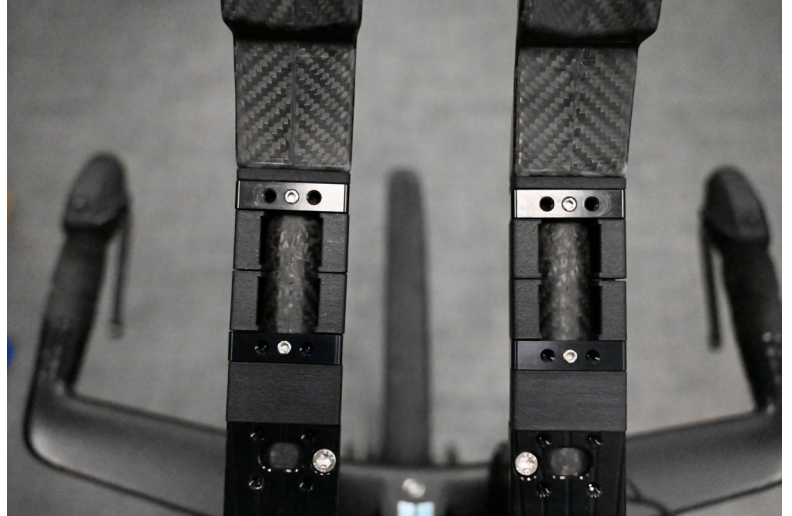

Step 2.b

Mounting with 1 armrest support

If your armrest is mounted with one arm rest supports like so. Skip steps 5 and 6

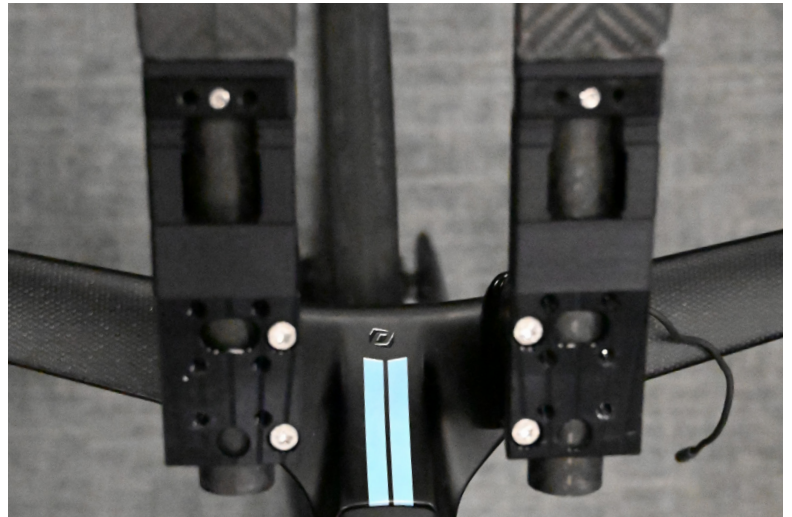



Step 3

Mount the BTA plates and stack clamp assembly onto your armrest centre bolt holes as below. Using only 2 countersunk bolts in the non-slotted BTA plate hole.

If your podiums are 110mm apart or less. Mount on the outer set of holes as shown below.

If your podiums are greater than 110mm apart. Mount on the inner set of holes as shown below. Tighten to 2Nm
Centre BTA stack clamps centrally between pole clamps and tighten to 2Nm. Tighten front bolts first

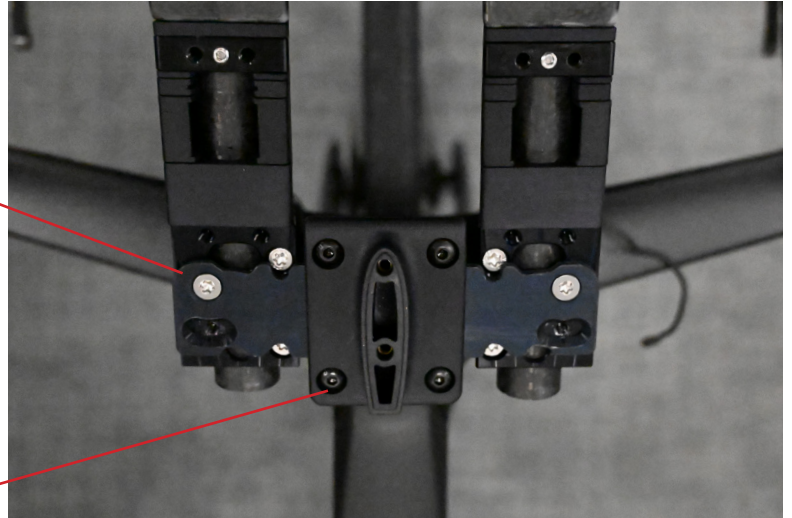

Mount on the outer set of holes as shown below.

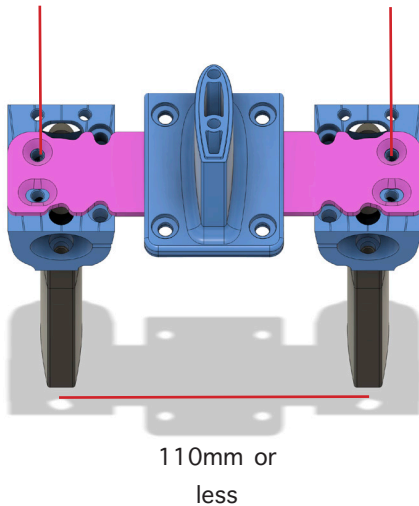

Mount on the inner set of holes as shown below.

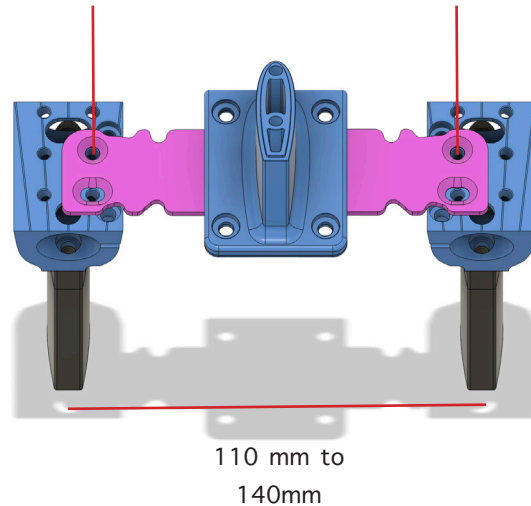

Step 4

Mount the armrest using the pre-supplied M5 button head bolts that come with your 66 kits.

One bolt goes into your arm rest support. The second into the pole clamp arm rest bolt hole. Tighten to 2Nm





Step 5

Mount the BTA plates and stack clamp assembly onto your armrest centre bolt holes as below. Using all 4 countersunk bolts.

If your podiums are 110mm apart or less. Mount on the outer set of holes as shown below.

If your podiums are greater than 110mm apart. Mount on the inner set of holes as shown below. Tighten to 2Nm
Centre BTA stack clamps centrally between pole clamps and tighten to 2Nm. Tighten front bolts first

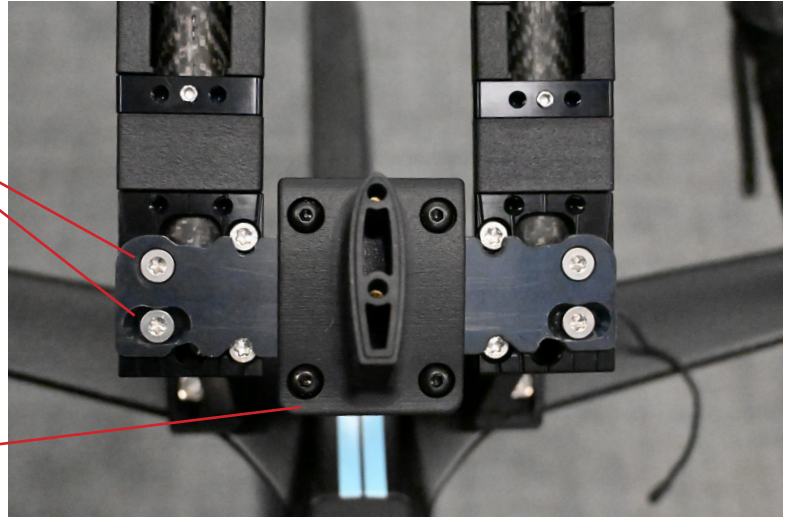

Mount on the outer set of holes as shown below.

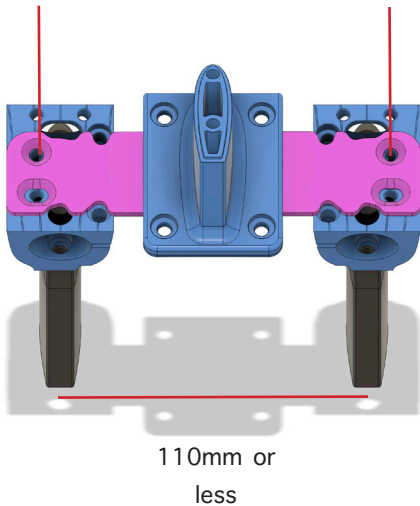

Mount on the inner set of holes as shown below.

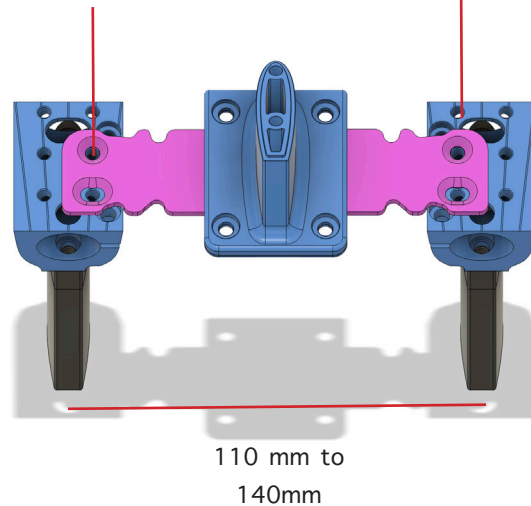

Step 4

Mount the armrest using the pre-supplied M5 button head bolts that come with your 66 kits.

One bolt goes into each arm rest support. The second into the pole clamp arm rest bolt hole. Tighten to 2Nm

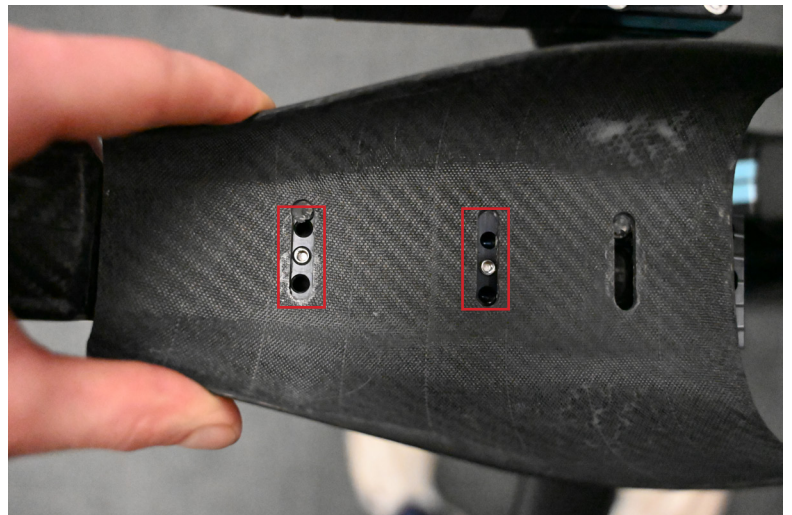

DRAG2ZERO



Step 7

Stick armrest foam down onto 66 armrests



Step 8

Mount BTA angled shim and BTA risers to BTA clamp assembly using corresponding M4 bolts below. Tighten to 2Nm

Spacers	Bolts
0mm to 10mm	30mm
20mm to 30mm	50mm



Step 9

Mount BTA bottle cage rail using M4 15mm bolts. Tighten to 2Nm



Step 10

Mount your bottle cage to the BTA bottle cage rail. Tighten to 2Nm





Step 11

Choose bottle position using the sliding barrel nuts. Tighten to 2Nm

