

DRAG2ZERO

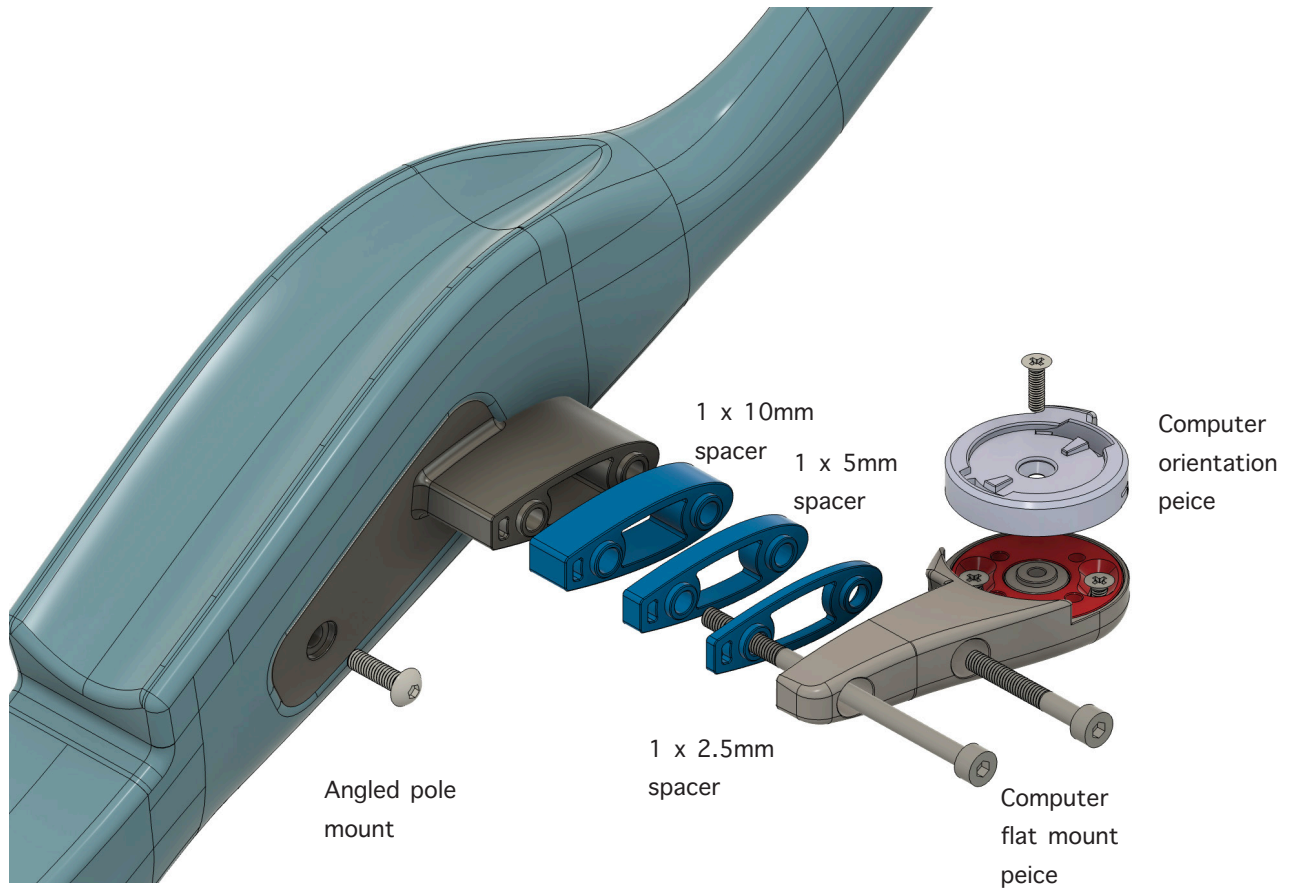

66 flat computer
mount





1. Replace the blacking panel with the desired angle mount onto the pole using the 1 x 16mm button head bolts already on the pole. Tighten to 2Nm.

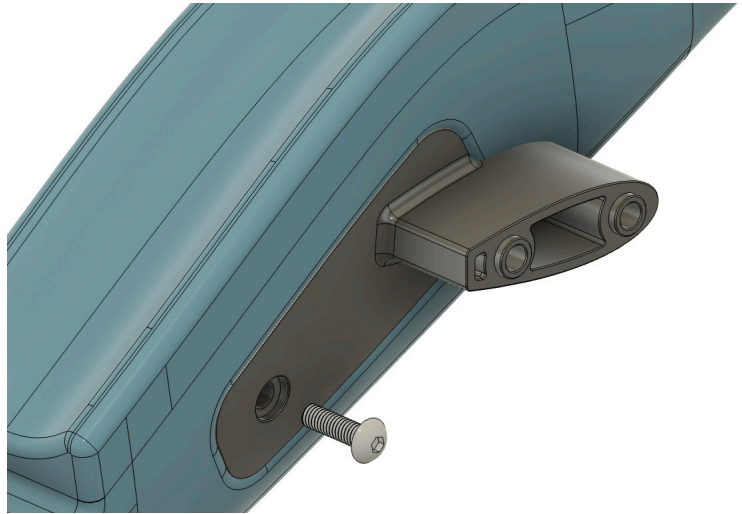

2. Find the required number of spacers until the computer mount is central between poles.

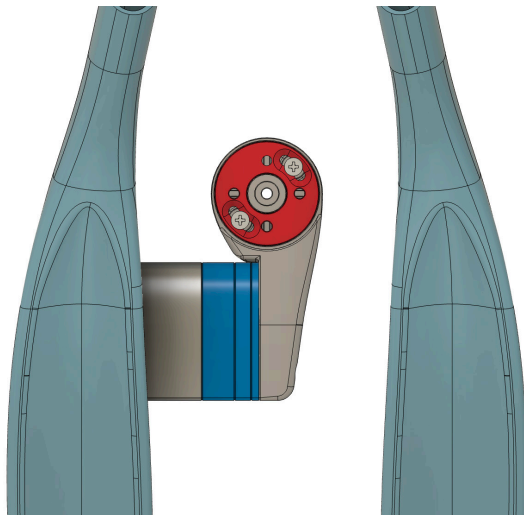

3. Bolt the flat computer mount piece onto the angle mount, sandwiching the spacers between. Tighten to 2Nm. Refer to the table below for bolt lengths.

Spacers	Bolts
0 - 2.5mm	50mm & 25mm
5 - 10mm	60mm & 35mm
12.5 - 17.5mm	70mm & 35mm

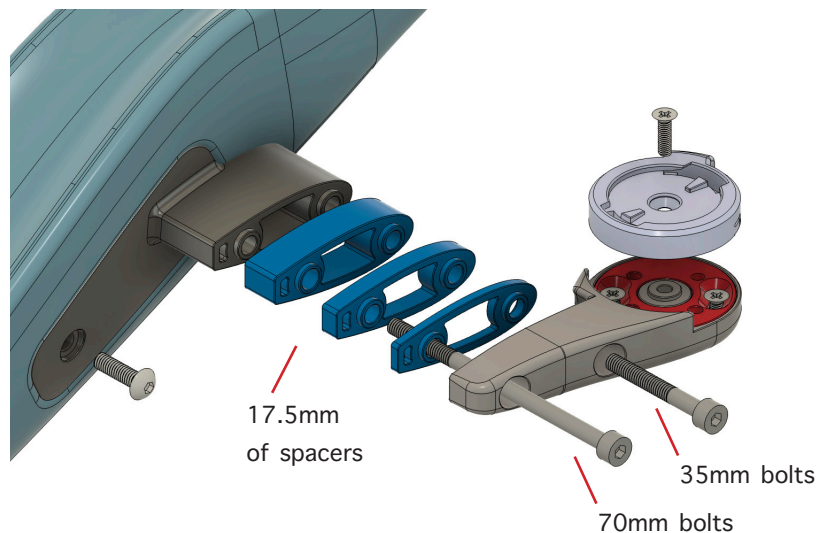

DRAG2ZERO



4. Loosen and rotate the computer toe adjustment piece until the holes point straight forward about the bike. Tighten to 2Nm

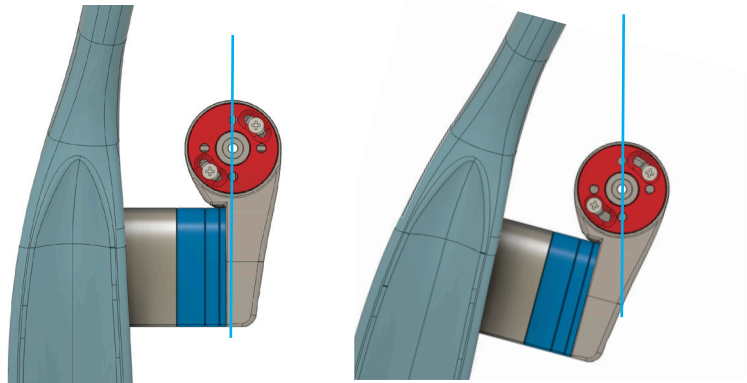

5. Mount either Garmin or Wahoo twist locking piece onto the mount, making sure locating pins are aligned as shown bellow. Tighten to 2Nm

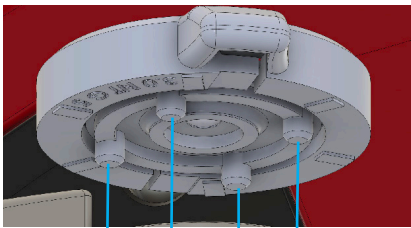

Wahoo piece

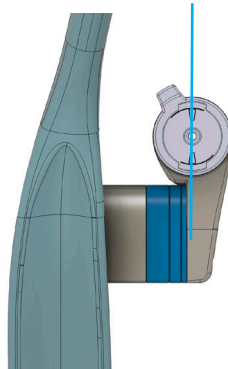

Garmin piece

